

The Ultimate Solution for PDU/LVDB/Load Center Monitoring Applications

- True RMS @ 128 Samples/Cycle*
- IEC 62053-22 Class 0.5S (Mains)
- IEC 62053-21 Class 1 (Branch)
- 2xMains Inputs each with 3xV & 4xI
- 21, 42, 63 or 84 Branch Circuits
- Support Solid-Core and Split-Core CT
- Possible In-Service Branch Expansion
- Mixing of 1- Φ , 2- Φ and 3- Φ Feeders
- 10 Virtual Meters (Aggregation)
- Dips/Swells Detection with WFR
- 8GB* Non-Volatile Log Memory
- Data, Energy & Event Recording
- Harmonics on Mains and all Branches
- Max. Demands and Max./Min.
- 4-Level Alarming - HH, H, L and LL
- 4xDI*, 2xDO and 2xTemp. Inputs
- Battery-backed Real-Time Clock
- Ethernet, RS-422/232/485
- Embedded Web Server
- HTTP, SMTP/SMTS, SNMP, SNMP V1/V2/V3*, IPv4/IPv6*, DNS*
- User Friendly 7" Color Touch Panel
- Industrial Grade Components
- Tropicalization & Extended Temp. Range

*The PMC-592 with Firmware V3.00.00 and later versions features following enhanced capabilities: True RMS sampling rate increased from 64 to 128 Samples/Cycle, extended log memory to 8GB, added 4xDI option, and SNMP V3/IPv6/DNS protocol support.

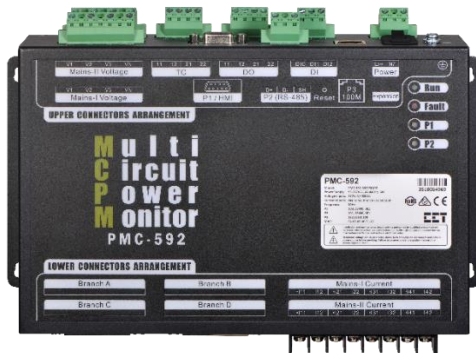

The PMC-592 MCPM is the ultimate solution for PDU, LVDB and Load Center applications that require multi-circuit monitoring. Housed in a compact metal enclosure, the PMC-592 is perfectly suited for applications that require high density metering. The PMC-592 features quality construction with multifunction and High-Accuracy measurements, two Mains Inputs, up to 84 Branch Circuit Inputs and an optional 7" Touch-Screen HMI. The PMC-592 comes with two or four Digital Inputs for status monitoring, two Digital Outputs for control or alarming as well as two RTD Inputs for temperature measurements. The standard SOE Log records all setup changes, Setpoint alarms and DI/DO operations in 1ms resolution. With dual RS-485 supporting Modbus RTU and an Ethernet port supporting HTTP, SMTP/SMTSPS, SNMP, V1/V2/V3, IPv4/IPv6 as well as DNS, the PMC-592 becomes a vital component of an intelligent, multi-circuit monitoring solution.

Typical Applications

- Data Center PDUs
- Clean room LVDB (Low-Voltage Distribution Board)
- Load Center Monitoring
- Ring Main Unit Metering
- Motor Control Center metering
- Commercial & Residential LV High-Density Multi-Circuit monitoring

Features Summary

Ease of use

- Status LEDs - Run, Fault, and Comm. activities
- Self-diagnostic function
- Password protected setup via its built-in Web Interface or optional HMI Display

Dual Mains Inputs

- 3-phase Voltage Inputs for 120VLN/208VLL, 220-240VLN/380-415VLL and 277VLN/480VLL systems
- 4-phase Current Inputs for 5A or 1A CT

Branch CT Inputs

- 100A Solid-Core CT Strip for new PDU installations
- 5A Solid-Core CT Strip for interfacing with external CTs with 5A secondary for LVDB/Load Center applications
- Supported CT Strips include 21x100A, 21x5A, 12x100A or 12x5A
- 50A~, 100A, 200A, 400A, 800A and 1600A Branch Split-Core CTs

Flexible Configuration

- Programmable CT Ratio and Polarity, Sub-Meter (SM) reference voltage, configurable 2- Φ & 3- Φ SM Grouping, CT Strip Orientation (Sequential or Crossover) and CT Strip Direction (Normal or Reverse)
- Support Single, Dual and Custom Panel Modes arrangement
- Programmable labels for ~ Device, Panel, 1- Φ & 2- Φ & 3- Φ SMs and VMs

Mains Measurements

- True RMS @ 128 Samples/Cycle~
- 2 Mains, each supporting 3 Voltage and 4 Current Inputs
- ULN and ULL per Phase and Average, Frequency
- I per Phase and Average, measured Neutral Current and Ir
- Voltage and Current Phase Angle~
- P, Q, S, PF per Phase and Total
- Loading Factor per Phase
- kWh/kvarh Import/Export/Net/Total, kVAh Total
- 2xRTD's Temperature and Resistance~
- Dual Tariff energy: kWh/ kvarh Import/Export/Net/Total, kVAh~

Branch Circuits Measurements

- 21, 42, 63 or 84 Branch Current Inputs
- I, P, Q, S, PF, Loading Factor
- Voltage and Current Phase Angle for 1- Φ SMs~
- kWh Import/Export/Net/Total, kvarh Import/Export/Net/Total, kVAh~

Demand Measurements

- Mains - I per Phase, P Total, Q Total, S Total
- Branch - I, P, Q, S per Circuit
- RTD1 and RTD2~
- Mains and Branches Max. Demands with timestamp for This Month & Last Month (or Since Last Reset & Before Last Reset)

Sub-Meters (SM)

- Support configurable 1- Φ , 2- Φ and 3- Φ SM
- I Average, Loading Factor, P, Q, S, PF Total, kWh/kvarh Import/Export/Net/Total and kVAh~
- Demand Values for I Average, P, Q and S
- Max. Demands with Timestamp for This Month & Last Month (or Since Last Reset & Before Last Reset)

Virtual Meters (VM)

- 10 configurable Virtual Meters for arbitrary aggregation of energy consumption from Mains and any of the (84) 1- Φ SMs
- Support both Addition and Subtraction.
- P, Q, S, kWh/kvarh Import/Export/Net/Total and kVAh per VM~
- Dual Tariff energy: kWh/kvarh Import/Export/Net/Total, kVAh Total~

Power Quality

- Mains Inputs
 - U and I Unbalance based on Sequence Components
 - U and I THD, TOHD, TEHD and Individual harmonics to 63rd~
 - Current TDD, TDD Odd, TDD Even, K-Factor and Crest Factor
 - Dips/Swells and Interruptions detection with Waveform Recording
- Branch Inputs
 - Current THD for each 1- Φ SM

Alarms

- Powerful alarming functions for Mains, Branches, RTDs and DIs (Expanded DIs included)
- Support High-High, High, Low, and Low-Low Alarms
- Support Phase Loss and Phase Reversal Alarms
- Configurable Threshold and Time Delay
- Support Global Alarm and Mains-I/II Total Summary Alarm Status
- Counters for all types of alarm
- All alarms are recorded in the SOE Log

Data and Event Recorders

Max./Min. Recorder

- Mains - U, I, Frequency, P, Q, S, Loading Factor, PF, Unbalance, THD, TOHD, TEHD
- RTD1 and RTD2
- 1- Φ SMs - I, P, Q, S, PF, Loading Factor and I THD
- 2- Φ and 3- Φ SMs - I, P, Q, S, PF and Loading Factor
- Max./Min. Timestamp for This Month & Last Month (or Since Last Reset & Before Last Reset)

Interval Energy Recorder

- Complete energy profiling of Mains-I/II, 1- Φ , 2- Φ and 3- Φ SMs, VMs as well as the Mains-I/II and VMs for Tariffs T1 and T2.
- Programmable Interval at 5, 10, 15, 30 or 60-minute intervals
- Fixed Log Depth at 10,000 entries, capable of recording:
 - 1 month @ 5-min interval
 - 2 months @ 10-min interval
 - 3 months @ 15-min interval
 - 6 months @ 30-min interval
 - 1 year @ 60-min interval

Waveform Recorder (WFR)

- Support up to 16 WFR Log entries
- Record U1-U3 and I1-I3 for both Mains-I and Mains-II
- Programmable resolution~ (samples/cycle x # of cycles) at 16x600, 16x300, 32x300, 32x150, 64x150 and 64x75
- Triggered by Dips/Swells and Interruptions

~These features have been enhanced since Firmware V3.00.00.



SOE Log

- 1000 events time-stamped to ±1ms resolution
- Setup changes, Power-On/Off, Alarms, Diagnostics and I/O operations

Data Recorders

- 8GB~ On-board eMMC log memory
- 10 Data Recorders of 64 parameters each for Real-time parameters
- Programmable Log Depth (65535 max.) and Recording Interval (60-345600s)

Inputs and Outputs

Digital Inputs

- Standard 2 or optional 4~ Channels, volt free dry contact, 24VDC internally wetted
- External status monitoring with programmable debounce
- 1000Hz sampling
- Tariff Switching based on DI Status for Main and GenSet accumulation

Digital Outputs

- 2 Channels for external control and alarm - 5A@250VAC/30VDC

RTD Input

- 2 Channels PT100 (sensor not included)

System Integration

- Supported by CET's PecStar® iEMS and iEEM
- Easy integration into other Automation, Energy Management, BMS or SCADA systems via Modbus RTU/TCP and SNMP

Terminals

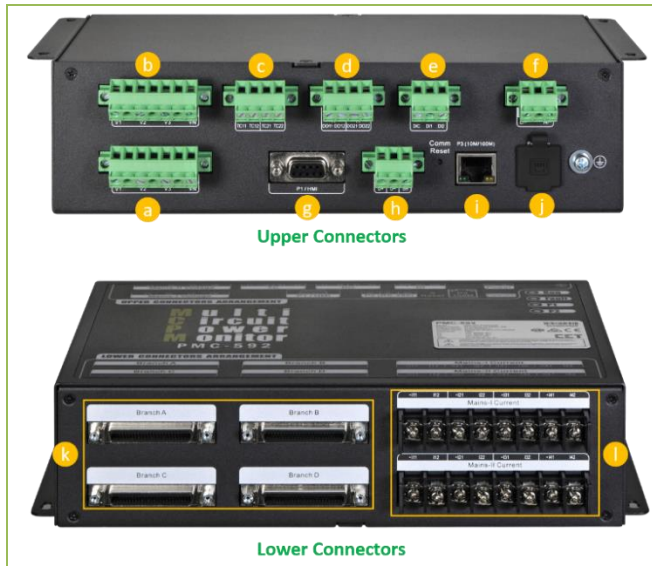

a	Mains I Voltage Inputs
b	Mains II Voltage Inputs
c	2xRTD Input
d	2xDigital Output
e	2xDigital Input
f	Power Supply
g	P1/HMI – DB9 Connector
h	P2 - RS-485 port
i	P3 - Ethernet port
j	Expansion port
k	Branch A to Branch D
l	Mains I and Mains II Current Inputs

Notes: The device appearance and height have been upgraded since hardware version V3.00.00.

Time Synchronization

- 6ppm battery-backed Real-Time Clock (<0.5s per day)

Communications

P1/HMI - DB9 Connector

- Modbus RTU
- Compatible with RS-232/422/485
- 1,200 to 115,200~ bps

P2 - RS-485

- Modbus RTU, Transparent Gateway & Modbus TCP to RTU Gateway~
- Optically or Capacitively Isolated
- 1,200 to 115,200~ bps
- Optional connection with up to 4 external DI Modules

P3 - Ethernet

- 10Base-T/100Base-TX
- Modbus TCP and Modbus RTU over TCP protocols, Modbus Gateway and Transparent Transmission~
- Supported protocols~: HTTP, SMTP/SMTSPS, SNMP, SNMP V1/V2/V3, IPv4/IPv6, DNS
- White List for Client Access Control
- Built-in password-protected Web Server, supporting log export~ (SOE, DR, Interval Energy Recorder, etc.) in CSV format
- Firmware upgrade via Ethernet port
- Configurable IP Port Number for Modbus TCP and HTTP

Accessories



~These features have been enhanced since Firmware V3.00.00.

Web Interfaces

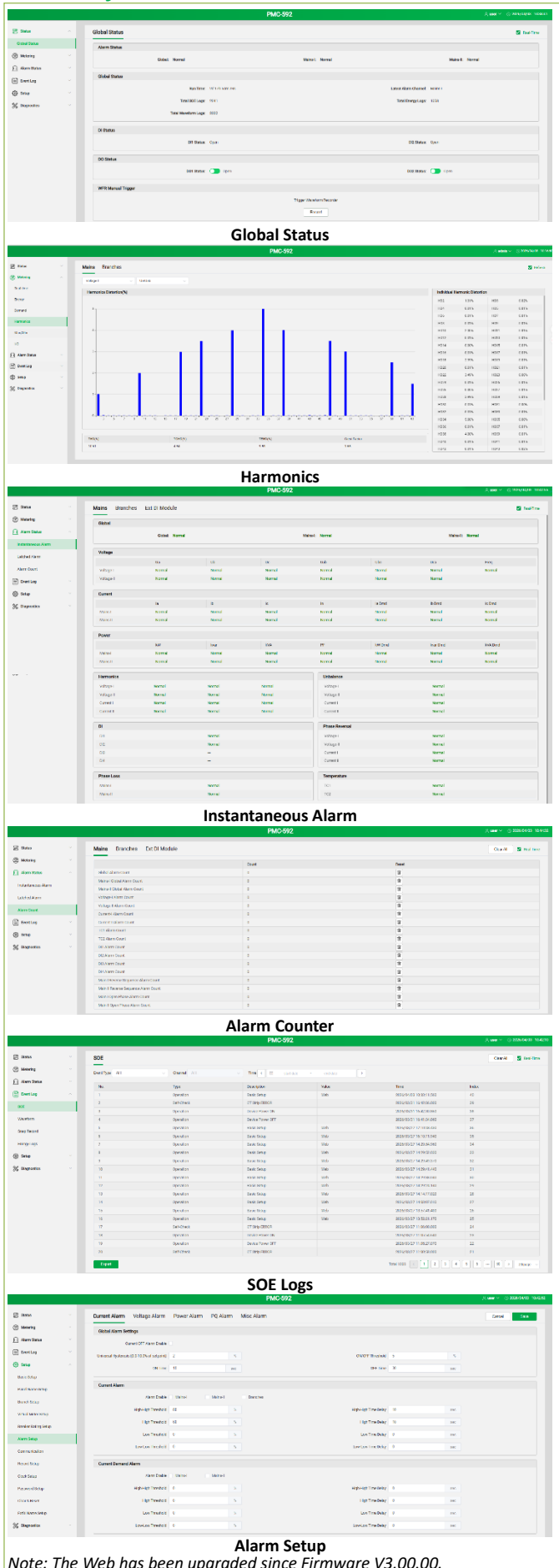

The web interface for the PMC-592 MCPM consists of several key sections:

- Global Status:** Provides an overview of the system's health, including global status, alarm status, and various input/output indicators.
- Harmonics:** Displays a bar chart showing the percentage of total harmonic distortion (THD) for various harmonics, with a table listing specific harmonic levels.
- Instantaneous Alarm:** Lists active alarms with details such as alarm type, description, and status.
- Alarm Counter:** Shows a summary of alarm occurrences, including the number of times each alarm type has triggered.
- Alarm Setup:** Allows for configuring alarm thresholds and settings for different parameters like voltage, current, and power.

Alarm Setup

Note: The Web has been upgraded since Firmware V3.00.00.

Technical Specifications

Main Voltage Inputs (V1, V2, V3, VN)		
Standard (Un)	277VLN/480VLL	
Range	10% to 120% Un	
PT Ratio	1-1,000,000V	
Mains I/II-Primary	1-480V	
Mains I/II-Secondary	1-480V	
Overload Burden	2xUn continuous, 4xUn for 1s	
Frequency	<0.05VA@277VLN per phase	
45-65Hz		
Mains Current Inputs		
I Nominal (In)	5A/1A (CT rated Input)	
Range	1% to 120%	
Starting Current	0.3% of In	
CT Ratio	6000 max. for 5A, 30000 max. for 1A	
Overload Burden	1.2xIn continuous, 10xIn for 1s	
<0.3VA per phase		
Power Supply for Main Unit (L+, N-)		
Standard	95-277VAC/DC, ±10%, 47-440Hz	
Optional	20-60 VDC (Available since FW V3.00.00)	
Burden	<6W	
Branch Inputs		
CT Ratio	400 Maximum	
Burden	<0.05VA per phase	
Starting Current	0.2% Imax	
Solid-Core CT Strip		
100A	In=50A, Imax=100A, Imin=0.8A	
10A	In=5A, Imax=10A, Imin=0.05A	
Split-Core CT		
50A	In=50A, Imax=60A, Range= 5%-120%	
100A	In=100A, Imax=120A, Range= 5%-120%	
200A	In=200A, Imax=240A, Range= 5%-120%	
400A	In=400A, Imax=480A, Range= 5%-120%	
800A	In=800A, Imax=960A, Range= 5%-120%	
1600A	In=1.6kA, Imax=1.92kA, Range= 5%-120%	
Solid-Core CT		
100A	In=100A, Imax=120A, Range= 5%-120%	
400A	In=400A, Imax=480A, Range= 5%-120%	
800A	In=800A, Imax=960A, Range= 5%-120%	
Digital Inputs (DI1, DI2, DIC or DI1, DI2, DI3, DI4, DIC)		
Type	Dry contact, 24VDC internally wetted	
Sampling	1000Hz	
Debounce	1-9999 ms programmable	
Digital Outputs (DO11, DO12, DO21, DO22)		
Type	Form A Mechanical Relay	
Loading	5A@250VAC/30VDC	
RTD Inputs (TC11, TC12, TC21, TC22)		
Type	PT100	
Range	-40 °C to 200 °C	
Environmental Conditions		
Operating Temp.	-25°C to +70°C	
Storage Temp.	-40°C to +85°C	
Humidity	5% to 95% non-condensing	
Atmospheric Pressure	70 kPa to 106 kPa	
Pollution Degree	2	
Overvoltage Category	CAT III	
Mechanical Characteristics		
Enclosure	Galvanized Steel	
Unit Dimensions	260.5(L)x154(W)x63.5(H)mm	
IP Rating	50	
Accuracy		
Parameters	Accuracy	Resolution
Mains Voltage	±0.2%	0.01V
Mains I1 - I4	±0.2%	0.001A
P, Q	IEC 62053-22 Class 0.5S for Mains	0.001kWh
kWh, kVAh	IEC 62053-21 Class 1 for Branches	0.1kWh
kvar, kvarh	IEC 62053-23 Class 2	0.001kvarh
	IEC 62053-24 Class 2	0.1kvarh
PF	±1%	0.001
Frequency	±0.02 Hz	0.01Hz
Harmonics	IEC 61000-4-7 Class II	0.01%
K-Factor	IEC 61000-4-7 Class II	0.01
RTD	±1.0°C	0.1°C



Standards of Compliance

Safety Requirements	
CE LVD Directive 2014 / 35 / EU	EN 61010-1: 2010 + A1: 2019 EN IEC 61010-2-030: 2021 + A11: 2021
Electrical Safety in Low Voltage Distribution Systems up to 1000Vac and 1500Vdc	IEC 61557-12: 2021 (PMD)
Insulation AC Voltage: 3.5kV@1 minute Insulation Resistance: >100MΩ Impulse Voltage: 6kV, 1.2/50μs	EN 61010-1: 2010 + A1: 2019
Electromagnetic Compatibility EMC Directive 2014 / 30 / EU (EN IEC 61326: 2021)	
Immunity Tests	
Electrostatic Discharge	EN 61000-4-2: 2009
Radiated Fields	EN 61000-4-3: 2020
Fast Transients	EN 61000-4-4: 2012
Surges	EN 61000-4-5: 2014 + A1: 2017
Conducted Disturbances	EN 61000-4-6: 2014 + AC: 2015
Magnetic Fields	EN 61000-4-8: 2010
Voltage Dips and Interruptions	EN IEC 61000-4-11: 2020
Oscillatory Waves	EN 61000-4-12: 2017
Immunity Standard for Industrial Environments	EN IEC 61000-6-2: 2019
Emission Tests	
Limits and Methods of Measurement of Electromagnetic Disturbance Characteristics of Industrial, Scientific and Medical (ISM) Radio-Frequency Equipment	EN 55011: 2016 + A1: 2017 + A11: 2020 + A2: 2021
Electromagnetic Compatibility of Multimedia Equipment - Emission Requirements	EN 55032: 2015 + A11: 2020 + A1: 2020
Limits for Harmonic Current Emissions for Equipment with Rated Current ≤16 A	EN IEC 61000-3-2: 2019 + A1: 2021
Limitation of Voltage Fluctuations and Flicker in Low-Voltage Supply Systems for Equipment with Rated Current ≤16 A	EN 61000-3-3: 2013 + A1: 2019 + A2: 2021
Emission Standard for Industrial Environments	EN IEC 61000-6-4: 2019
Mechanical Tests	
Spring Hammer Test	IEC 62052-31: 2015
Vibration Test	IEC 62052-11: 2020
Shock Test	IEC 62052-11: 2020

Main Unit Dimensions and Installation

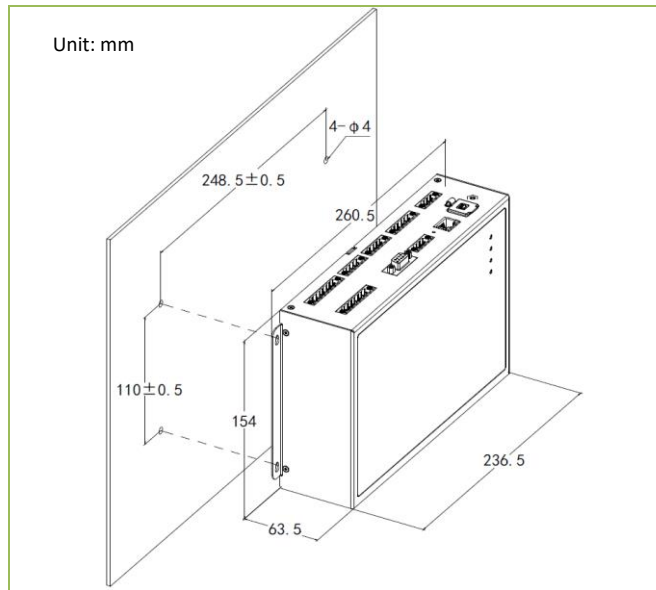

Branch CTs Dimensions

Split-Core CTs

PMC-SCCT-xxxxA-40mA-x-A

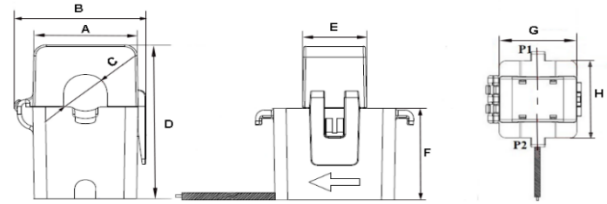

Dimension (mm)	A	B	C	D	E	F	G	H
PMC-SCCT-50A-40mA-16-A	30	36.3	16	47	19	26.5	30	32
PMC-SCCT-100A-40mA-16-A	30.26	38	16.1	48.9	19.9	28.6	30.7	33.9
PMC-SCCT-200A-40mA-24-A	44.3	53.5	24.1	70	20	40.5	45	40.2
PMC-SCCT-400A-40mA-35-A	57.3	67	35.1	83	22.5	47	58.2	42.8

Notes: PMC-SCCT-50A-40mA-16-A is available since Firmware V3.00.00

PMC-SCCT-xxxxA-40mA-A

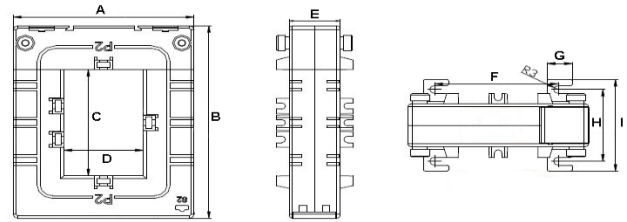

Dimension (mm)	A	B	C	D	E	F	G	H	I
PMC-SCCT-800A-40mA-A	114	145	80	50	32	77	16	50	65
PMC-SCCT-1600A-40mA-A	143.2	191	129	55	49.2	108	15.8	54	69

Solid-Core CTs

PMC-CT-100A-40mA-12-A

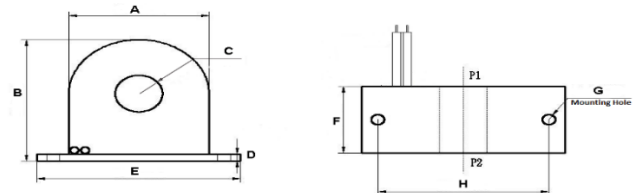

Dimension (mm)	A	B	C	D	E	F	G	H
PMC-CT-100A-40mA-12-A	35.8	40	12	2.4	51.5	22	3.3	43.5

PMC-CT-400A-40mA-A

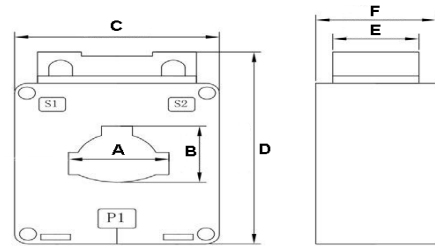

Dimension (mm)	A	B	C	D	E	F
PMC-CT-400A-40mA-A	31	24	59	78.5	27.5	30.5

PMC-CT-800A-40mA-A

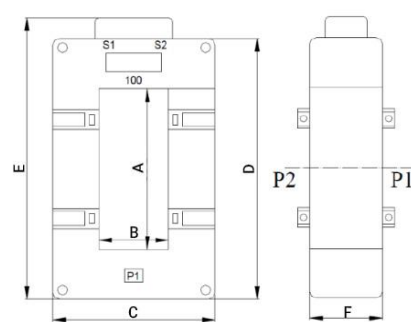

Dimension (mm)	A	B	C	D	E	F
PMC-CT-800A-40mA-A	103	33	105	175	191	56



Optional HMI Dimensions and Installation

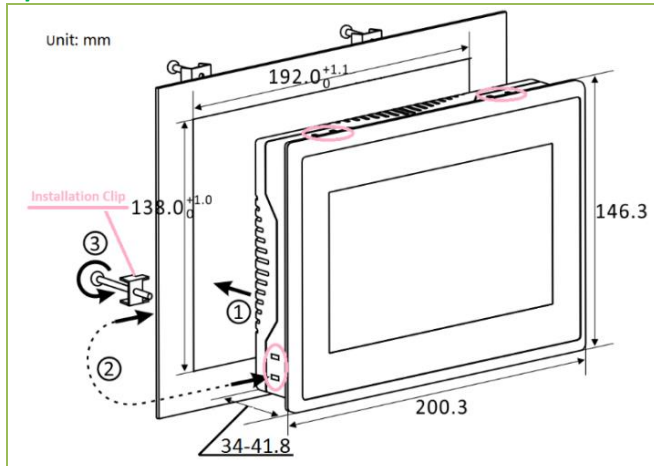

Ordering Guides

Main Unit

Product Code		Description
PMC-592 Multi Circuit Power Meter		
Functionality		
A		The PMC-592 Base Unit comes with 2xMains inputs, each with 3-phase Voltages and 4-phase Currents, 2xRTD inputs, 2xDI, 2xDO, 1xRS-422/485 Port (HMI Interface), 1xRS-485 Port and 1x10Base-T/100Base-TX Ethernet Port. It supports up to 4 CT Branches with a maximum 21 CTs per Branch.
B		The PMC-592 Base Unit comes with 2xMains inputs, each with 3-phase Voltages and 4-phase Currents, 2xRTD inputs, 4xDI, 2xDO, 1xRS-422/485 Port (HMI Interface), 1xRS-485 Port and 1x10Base-T/100Base-TX Ethernet Port. It supports up to 4 CT Branches with a maximum 21 CTs per Branch.
Current Rating for the 2 Mains Feeders		
5		5A: Standard
1		1A
Voltage Rating for the 2 Mains Feeders		
3		277VLN/480VLL
Control Power Ratings		
2		95-277 VAC/DC, 47-440Hz
3		20-60 VDC
Power System Frequency		
5		50Hz
6		60Hz
Current Rating for Branch Feeders		
100		For use with 100A Fixed Core CT Strip or with CT Adapter Board and 50A-1600A Branch SCCTs
010		For use with 10A Fixed Core CT Strip only
Langue Version for Front Plate		
E		English: Standard for International
PMC-592	-	A 5 3 2 5 100 E
PMC-592-A5325100E (Standard Model)		

- 1) The PT100 sensor for the RTD input is an optional item.
- 2) Please refer to PMC-592 Accessories for the PT-100 sensor, Branch SCCT, Branch CT Strip, CT Adapter Board and Branch Circuit Cable options.
- 3) The PMC-592's HMI with 7" LCD with 24VDC power supply module is an optional item.
- 4) Please refer to the PMC-592 Accessories for the different options of Branch Circuit Cable Length for connecting the Main Unit to the CT Strip or the SCCT Adapter Board. The Branch Circuit Cable must be ordered separately and can be ordered with different cable length for each Branch Circuit. Please order one Branch Circuit Cable for each Branch.

HMI (Optional)

Product Code		Description
PMC-592-HMI		
Basic Function		
A		7" TFT LCD, 800x480, 1xRS-422/485 port, a RS-422 cable and an external 24VDC Switching Power Supply
C		Same as 'A' but supports two PMC-592 (168 feeders)
D		Same as 'A' but supports four PMC-592 (336 feeders)
Interface Language		
E		English
PMC-592-HMI	-	A E
PMC-592-HMI-AE (Standard Model)		

*The standard cable length for connecting the HMI to the PMC-592 Main Unit is 3.0m. Please contact the factory in advance for special requirements.

Accessories

VersionA 20260103					
PMC-592 Accessories					
Branch CT Strips					
Model #	Specifications	Accuracy	Inner Diameter		
PMC-CTS-21A100	21 Fixed Type CT, 100A, 3/4" spacing	0.1	11mm		
PMC-CTS-21B100	21 Fixed Type CT, 100A, 1" spacing	0.1	11mm		
PMC-CTS-21A010	21 Fixed Type CT, 10A, 3/4" spacing	0.1	11mm		
PMC-CTS-12A100	12 Fixed Type CT, 100A, 3/4" spacing	0.1	11mm		
PMC-CTS-12A010	12 Fixed Type CT, 10A, 3/4" spacing	0.1	11mm		
CT Adapter Board for Split-Core CT					
Model #	Description				
PMC-CT-ADB	To connect up to 21 individual Split-Core or Solid-Core CTs to this board				
Branch Circuit Cable					
Model #	Cable Length	Diameter	Max. Resistance at 20°C		
PMC-BCC-0.4	0.4m	8.2mm	237Ω/km		
PMC-BCC-1	1.0m	8.2mm	237Ω/km		
PMC-BCC-1.8	1.8m	8.2mm	237Ω/km		
PMC-BCC-3	3.0m	8.2mm	237Ω/km		
PMC-BCC-6	6.0m	8.2mm	237Ω/km		
PMC-BCC-10	10.0m	8.2mm	237Ω/km		
Optional Split-Core CT for Branch Circuits					
Split-Core CT Model #	Current Ratio	Accuracy	Aperture (mm)	Output Wire Length	Load
PMC-SCCT-50A-40mA-16-A	50A/40mA	0.5	Ø16	2m	20Ω
PMC-SCCT-100A-40mA-16-A	100A/40mA	0.5	Ø16	2m	20Ω
PMC-SCCT-200A-40mA-24-A	200A/40mA	0.5	Ø24	2m	10Ω
PMC-SCCT-400A-40mA-35-A	400A/40mA	0.5	Ø35	2m	10Ω
PMC-SCCT-800A-40mA-A	800A/40mA	0.5	80x50	Not included	10Ω
PMC-SCCT-1600A-40mA-A	1600A/40mA	0.5	129x55	Not included	10Ω
Optional Solid-Core CT for Branch Circuits					
Solid-Core CT Model #	Rating	Accuracy	Aperture (mm)	Output Wire Length	Load
PMC-CT-100A-40mA-12-A	100A/40mA	0.2	Ø12	2m	20Ω
PMC-CT-400A-40mA-A	400A/40mA	0.2	31x24	Not included	20Ω
PMC-CT-800A-40mA-A	800A/40mA	0.2	103x33	Not included	20Ω
Optional PT100 Sensor					
PT100 Model #	Cable Length				
WZPT-1031	3m				

CET Electric Technology Inc.

E: sales@cet-global.com

W: www.cet-global.com

Your Local Representative

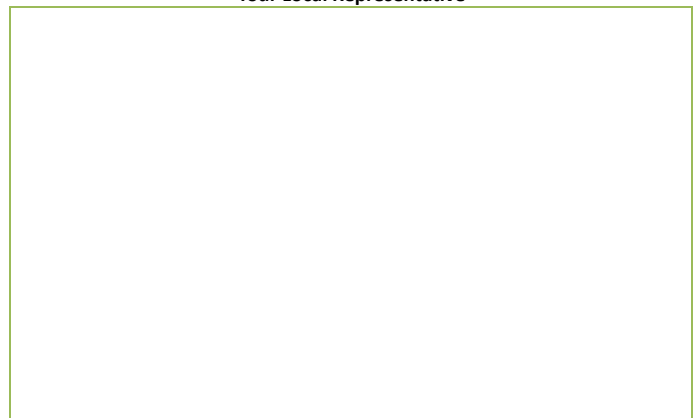

Revision Date: April 3, 2026